

1 Door Access Control Panel

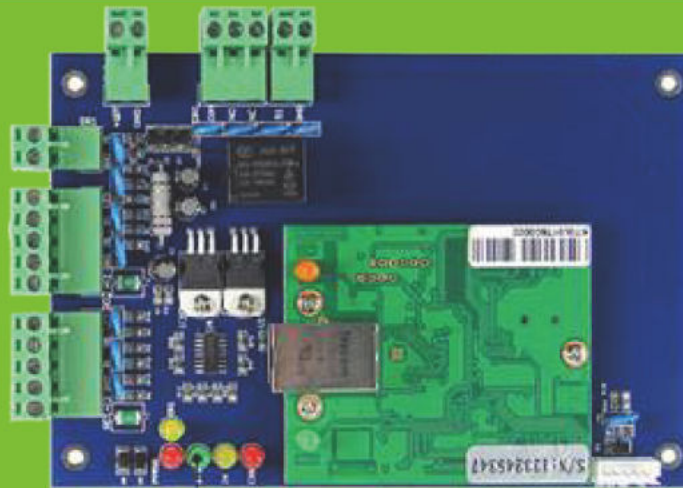

Specifications

Parameter	Single Door Control Panel
Model #	
Communication	TCP/IP 10M/100M adaptive
Description	Control 1 door, get in and out door by swiping card, or get in by swiping card and get out door by button
Size of PCB board	160mm*106mm
Size of Case	273mm*228mm*65mm
Power Supply	12VDC 4-7A
Power Consumption of Circuit Board	Less than 100mA
Input Format of Reader	Wiegand 26
Quantity of Readers	2 pcs
Door Controlled	1 door
Door opening time extending setting	1-600 seconds(adjustable)
Max q' ty of controller	No limit

Operation Temperature	40℃~70℃
Operation Humidity	10 90 % RH , No Condensation
Q' ty of users	20,000 Users
Q' ty of Event Buffers (offline)	100,000 event buffers
Power interruption protection measure	High Speed Memory, Records never lose
Max Distance from Reader to Controller	100m (suggestion distance 80m)
Max Distance between Controllers	TCP/IP: Depends on net coverage area
Package included	PCB board, software, manual, certificate. carton
Alarm for long time door open, ilegal break in, intimidate	Yes
Fire and alarm linkage	If no connection with the expansion board, only has software interface alarm, and drive the computer speaker. If connected with expansion board, is able to alarm by hardware, if connected with strengthened expansion board, then is able to Security alarm.
Complisive open and close door at long time	Yes
Open door in remote distance	Yes
Inter block	
Anti pass back and tail	Yes
Multi-card open door	Yes
Open long time at specified time	Yes
Electronic map	Yes
Urgency locking	Yes
First card unlocking	Yes
Unlock based on internal and external validation	Yes
Keypad (card+passwor, supper password)	Yes

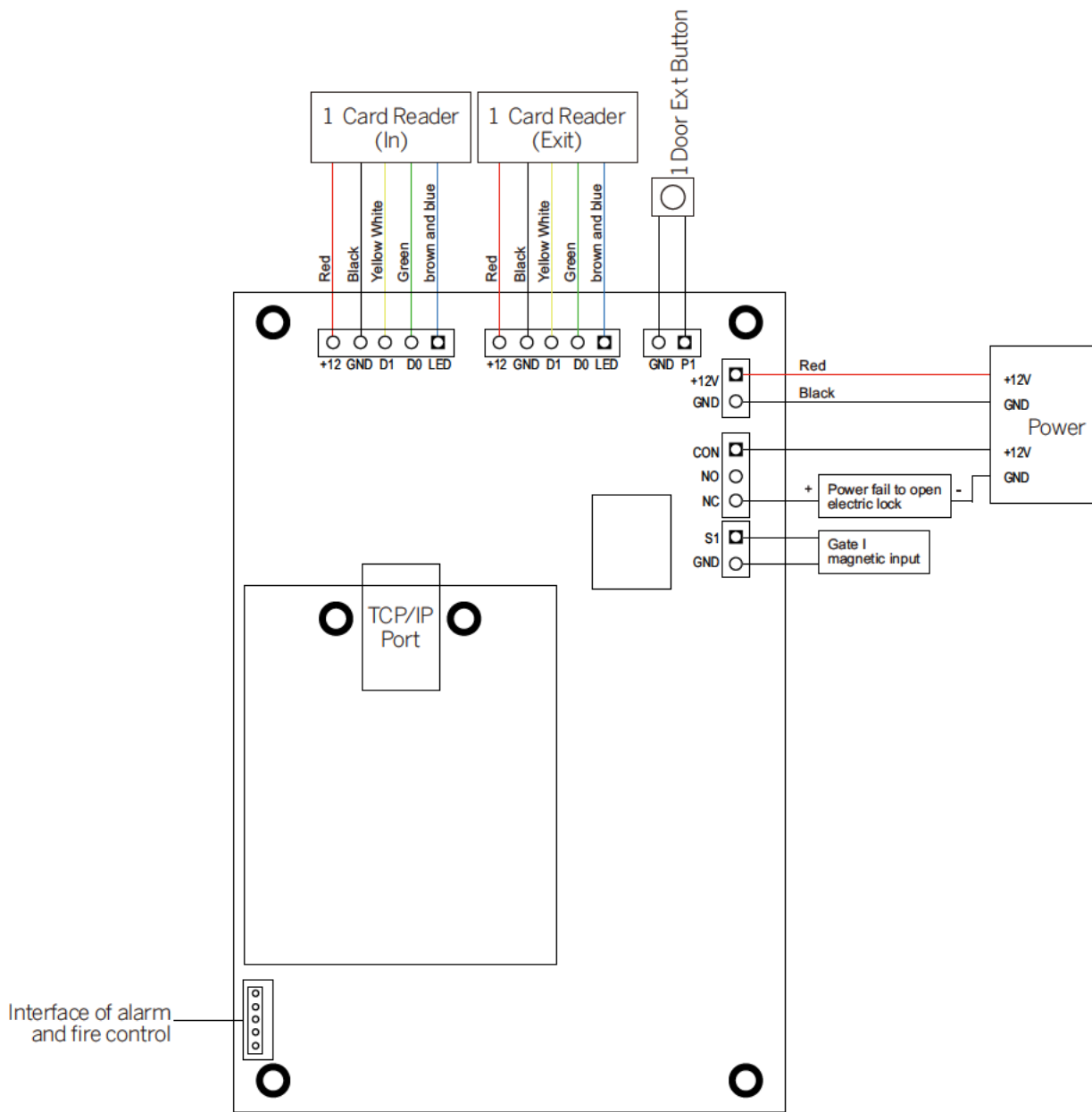

Wiring standard

(Even the connection distance is very short, it must be implemented according to the following requirement)

+220V AC Power cable:

The wire power supply, the cross sectional area 1.0mm or more. It's required that power supply must be grounded to prevent from power interference

+The line of electric lock to controller:

It's recommended to use two wire power line, the cross sectional area 1.0mm² or more. If the distance over 50 meters, it's considered to use thicker line or multiple parallel

+TCP/IP Communication Line:

Network cable

+The card reader, door sensor and button line:

Can use network cable or others