

MA-EL102

Features

- Material: Aluminum
- Mount Adapter
- Neat & Integrated design



Dimensions (mm)

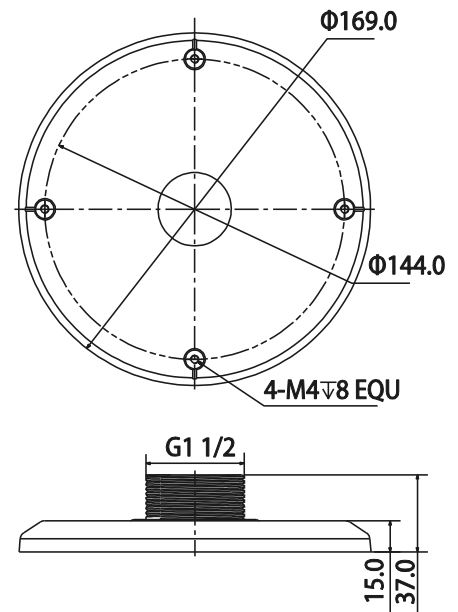

Specifications

Model	A 5! 9@/\$&
General	
Material	Aluminum
Dimension (W x H x D)	φ169mm x 37mm
Pipe Thread	G1 _{1/2} "
Operating Temperature	-40°C ~60°C
Humidity	0~90% RH
Load Bearing	N/A
Weight	0.25Kg
Applicable Model	Please see "Accessory Selection"

Application

