

WM-EL305W

Wall Mount Bracket



Features

- Material: Aluminum
- Wall Mount Bracket
- Neat & Integrated design

Dimensions (mm)

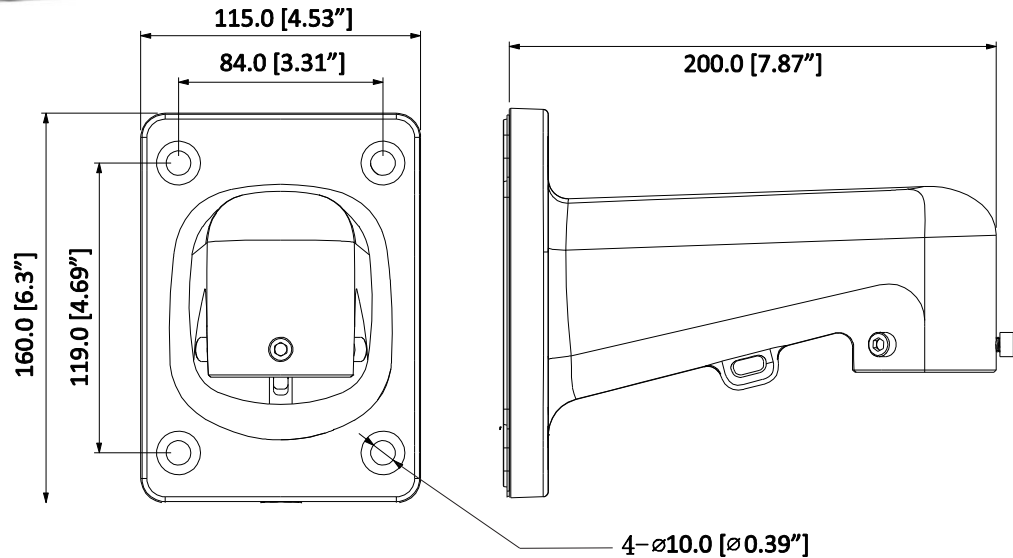

Specifications

Model	WM-EL305W
General	
Material	Aluminum
Dimension(WXHXD)	200mmx160mmx115mm(7.87"x6.3"x4.53")
Weight	0.87kg(1.92lb)
Load Bearing	5.0kg(11.02lb)
Color	White
Operating Temperature	-40°C ~60°C(-40°F ~140°F)
Humidity	<90% RH

Application

